

REGISTRATION PROCESS IN RELIEF PRINTMAKING

Mark Watke

Draftsman, Painter, Illustrator

North Augusta, SC

Registration

A matrix measured 10 in x 12 in fits inside a 15 in x 17 in design with 2.5 in borders.

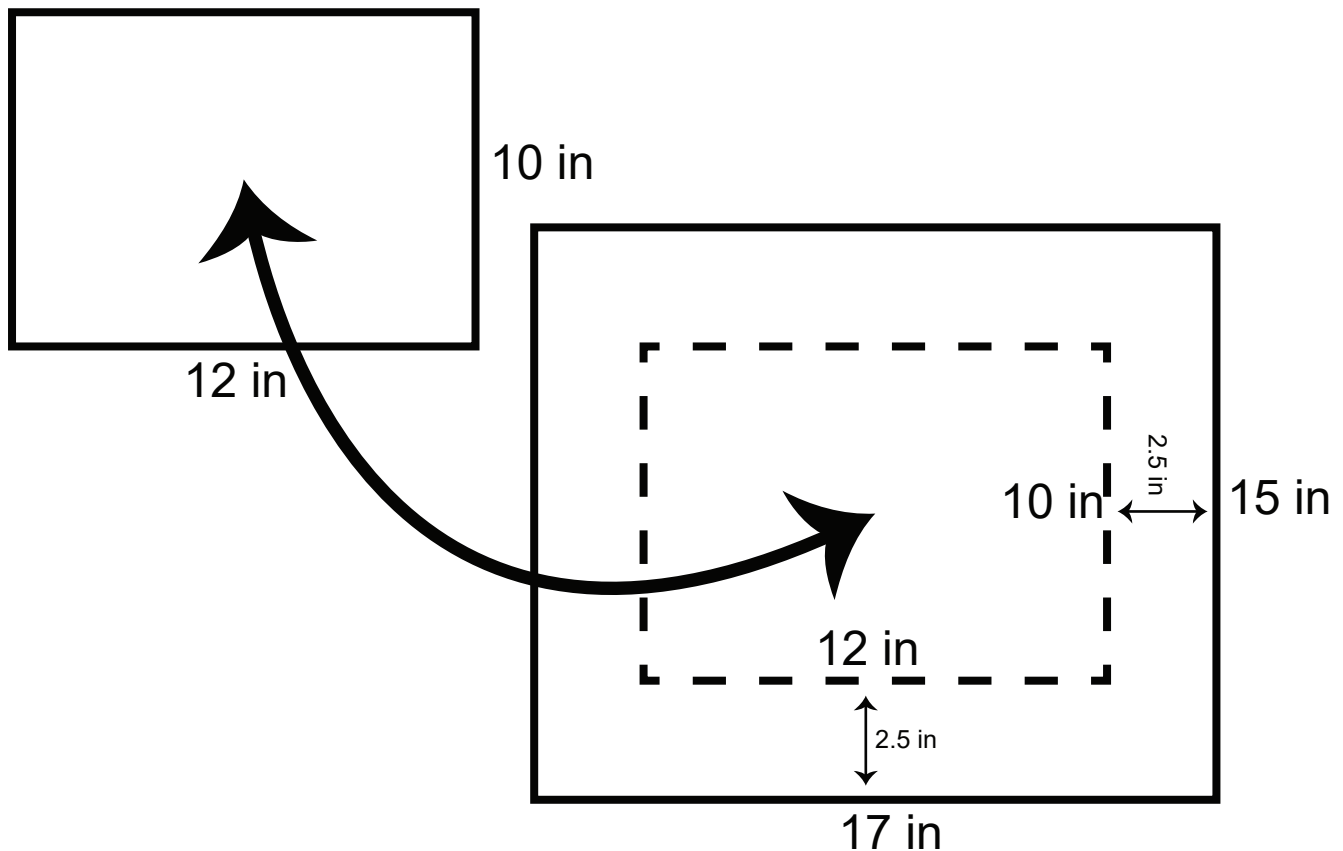

The first step in registration is obtaining a sheet of paper. If you are in Chadwick Tolley's class he will give you a sheet of paper which you have to cut yourself. I got several drawing pads for Christmas so I have been using those for printmaking.

Most any type of paper should work, though some thicker papers could affect press pressure. Some non archival papers may include complex organic polymers that cause paper to degrade. These sorts of papers are usually used for printing newspapers. The most notable example for of this kind of paper for the artist is newsprint.

These polymers are typically removed in industrial processes that produce archival papers. Lignin is a polymer that exists in the secondary wall of a plant cell along with cellulose.

Degradation of newsprint paper is caused by lignin in the presence of sunlight and air.

The sulfite process uses salts of sulfurous acid to extract lignin resulting in paper that contains exclusively cellulose fibers

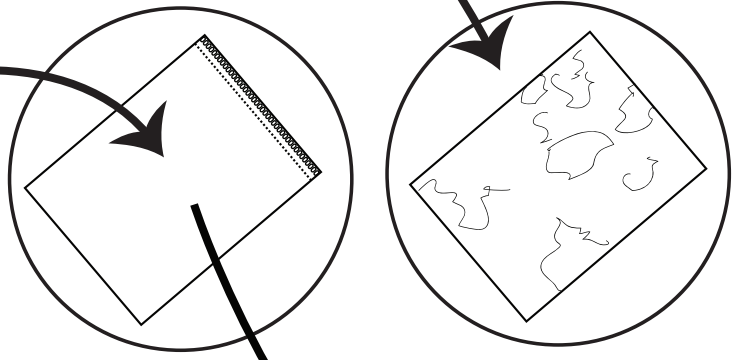

Strathmore drawing paper
24 sheets 400 series best

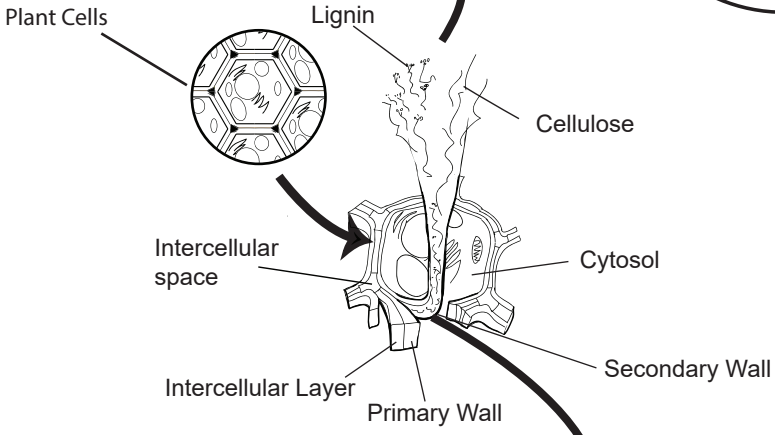
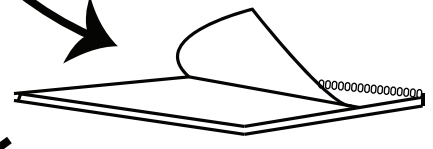

Lignin exists inside the secondary wall bordering the plasma membrane

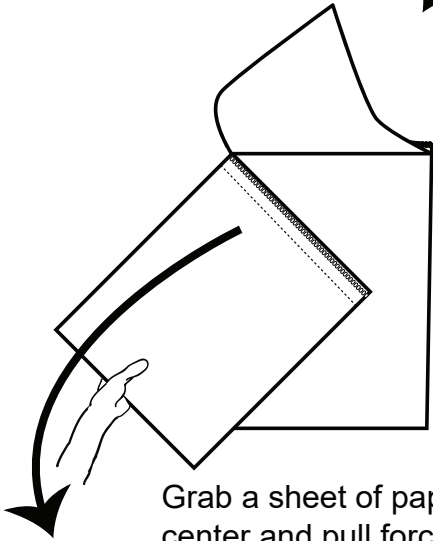

Grab a sheet of paper at its center and pull forcefully to separate it from the rest of the bound drawing pad.

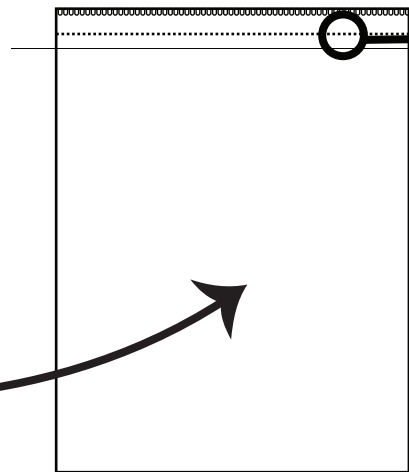

The precut lines at the top must be removed before the paper is trimmed to fit the specifications for print.

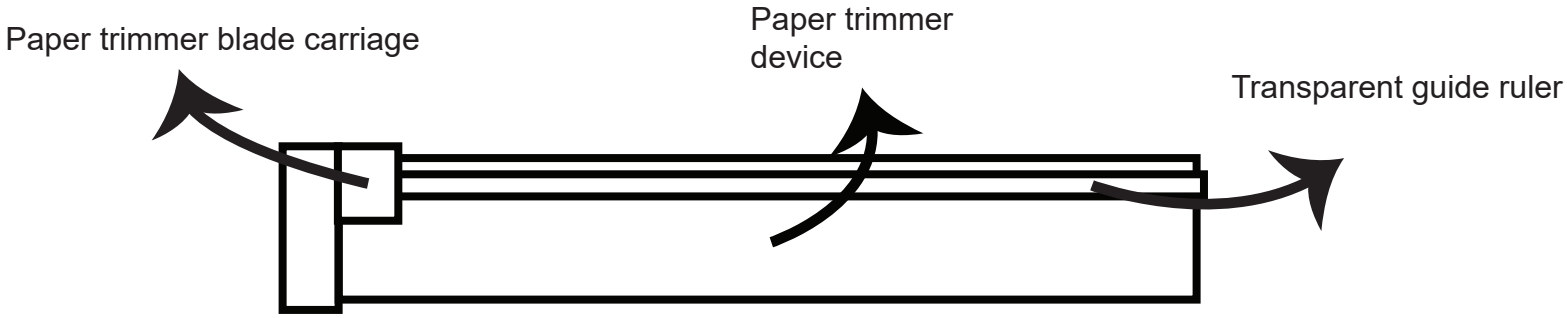

Move the paper trimmer blade carriage to the right, exceeding the maximum measurement of your to be cut paper

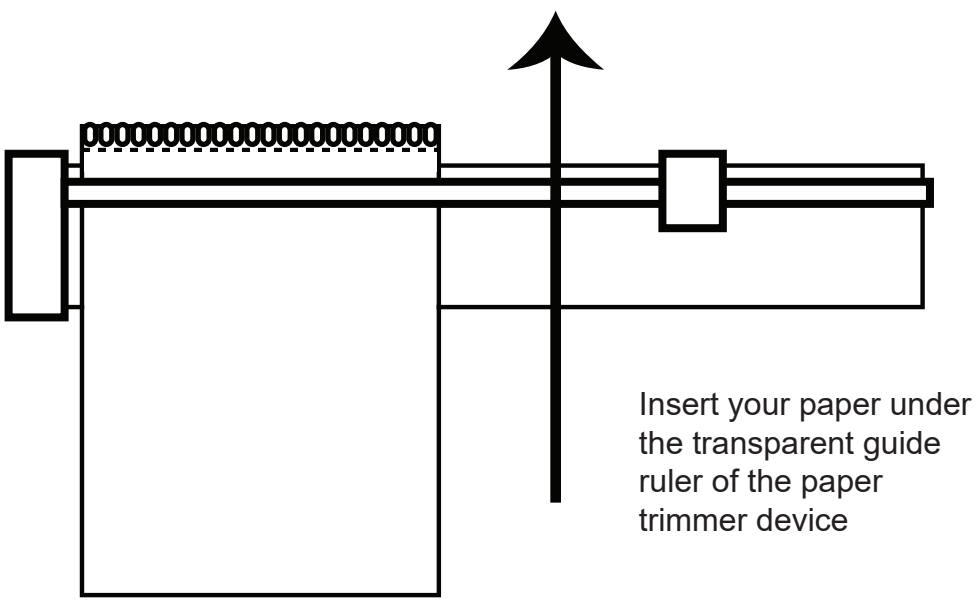
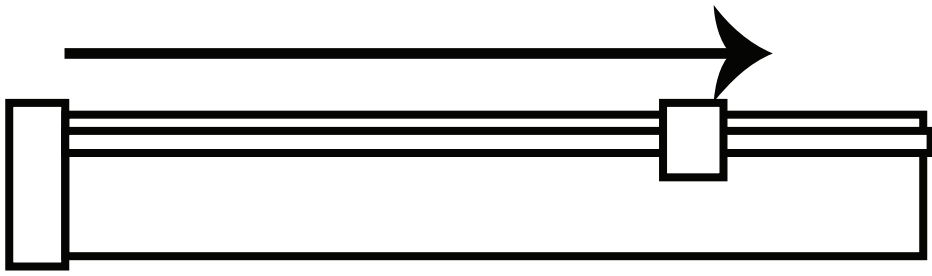

The precut lines at the top must be removed before the paper is trimmed to fit the specifications for print.

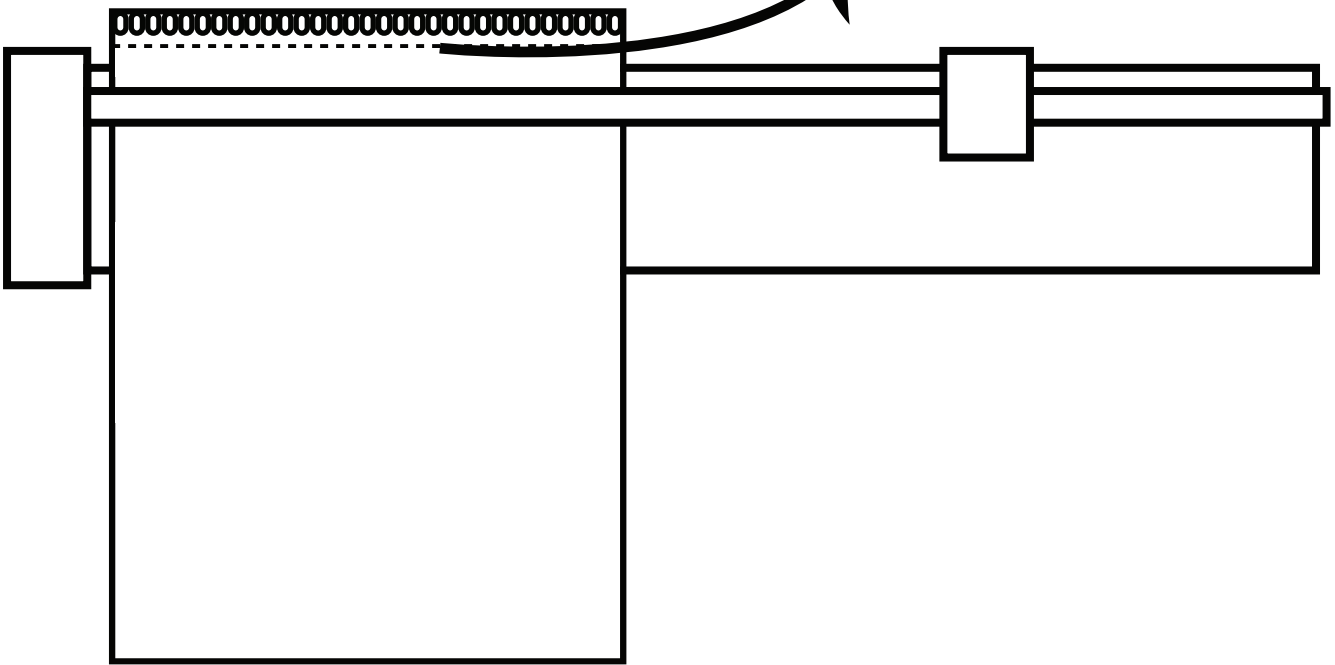

Grasp the paper trimmer blade carriage and force it to the left through the paper to cut off the excess

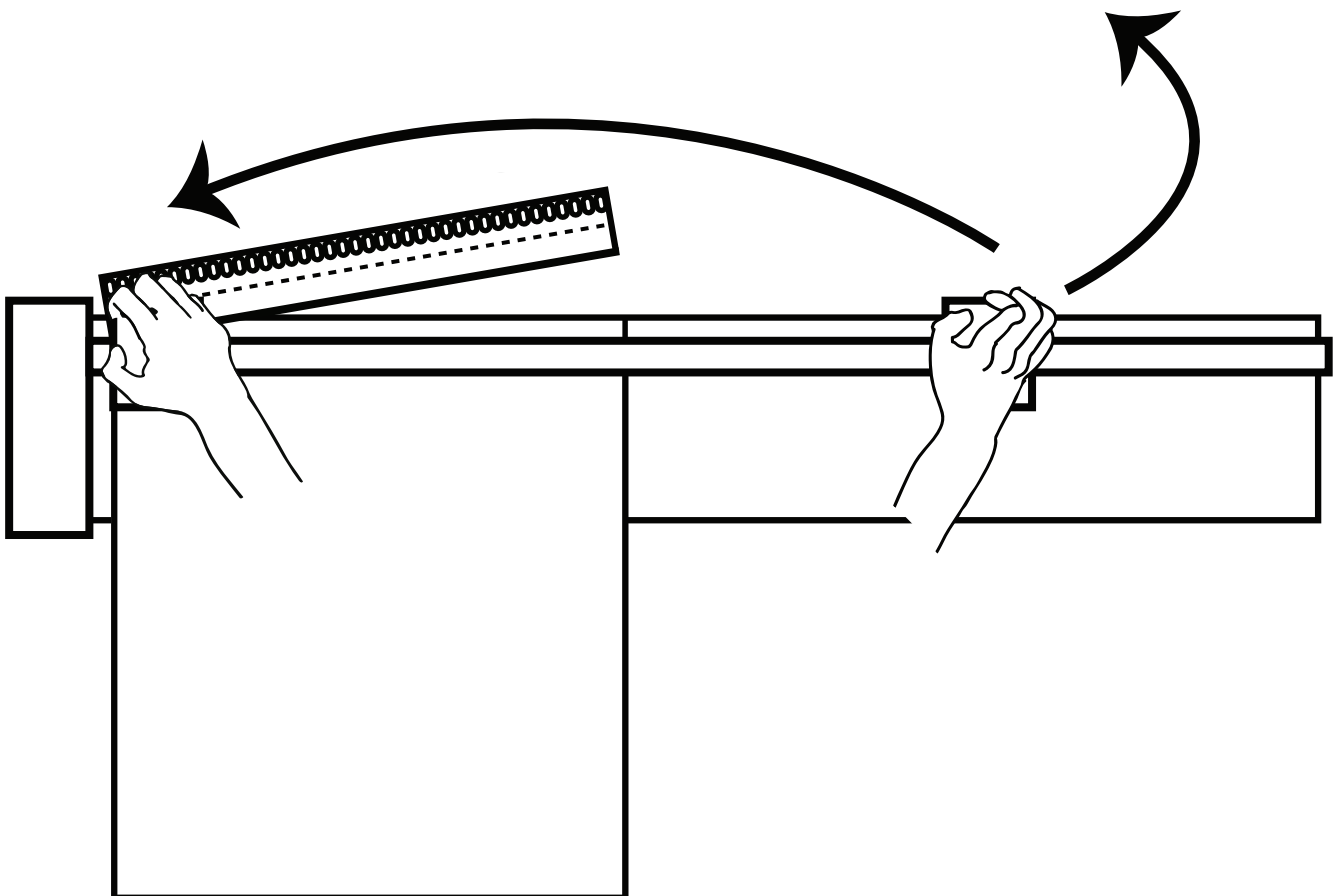

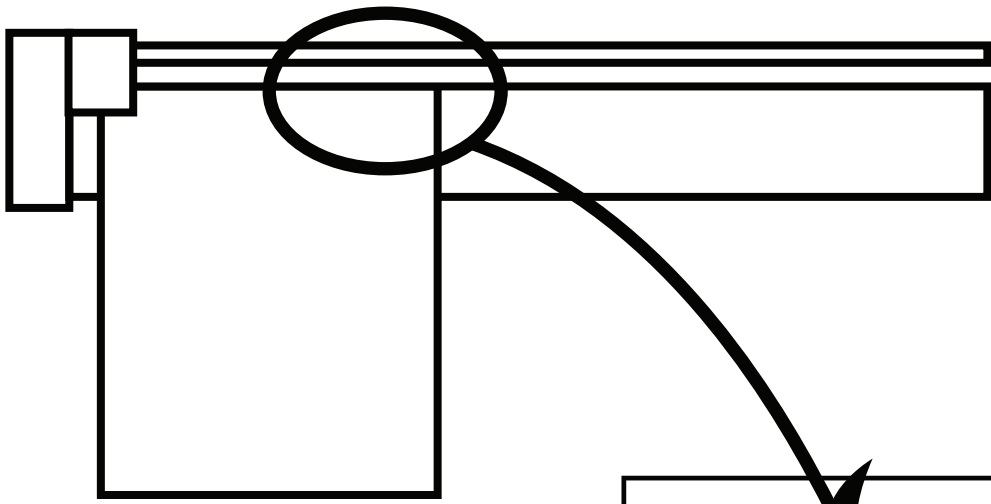

Mark the paper at 15 inches using a ruler as a straight-edge.

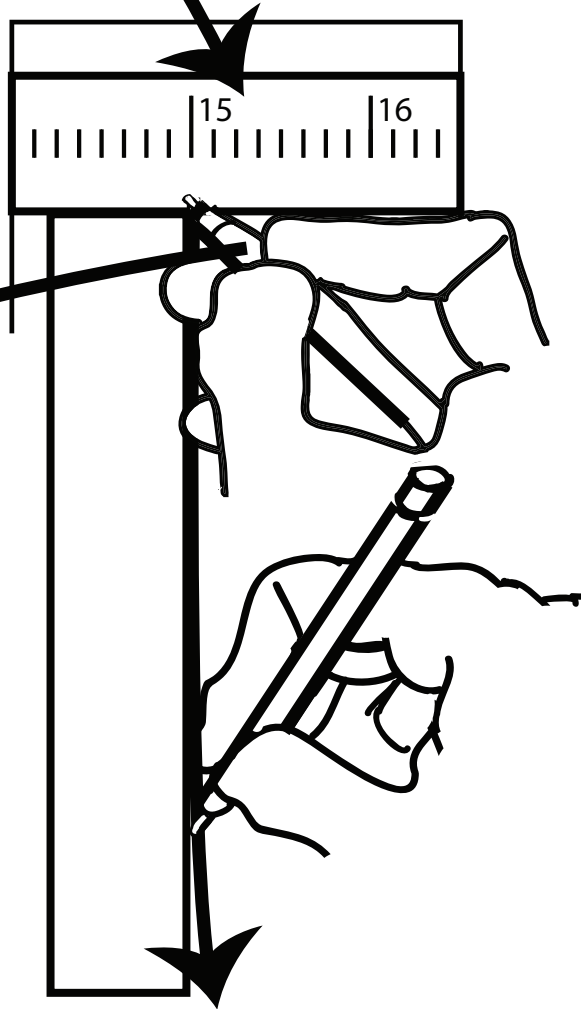

When you are making marks for registration, be sure to use a mechanical pencil to minimize the ambiguity created by the line weight of thicker writing instruments

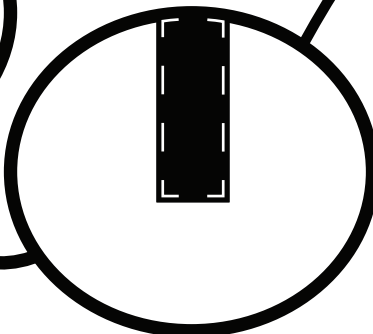
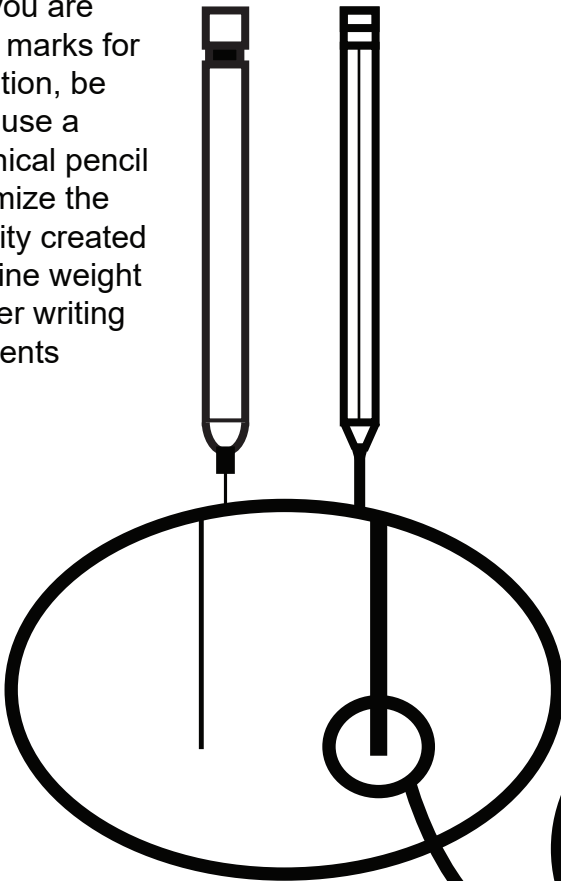

As you can see, the thicker the line created by a writing instrument, the more significant its boundaries become in defining the produced line. This is important to avoid, as the thicker the line, the more perceptual the process of interpretation.

Move the paper trimmer blade carriage to the right to exceed the maximum measure of your paper.

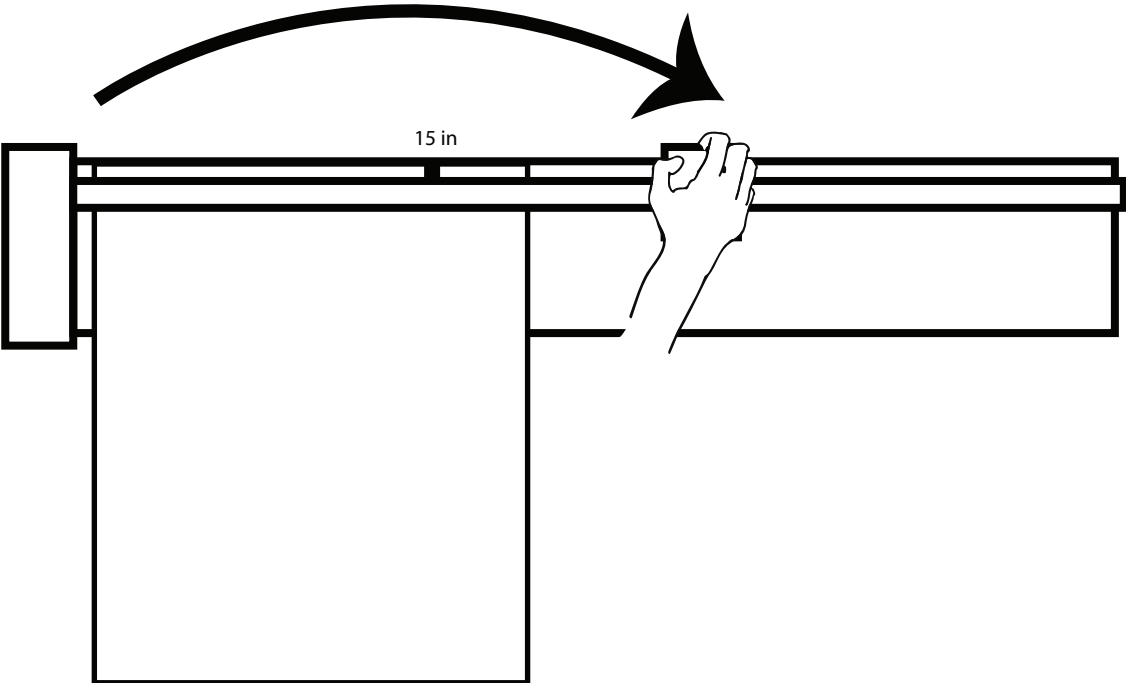
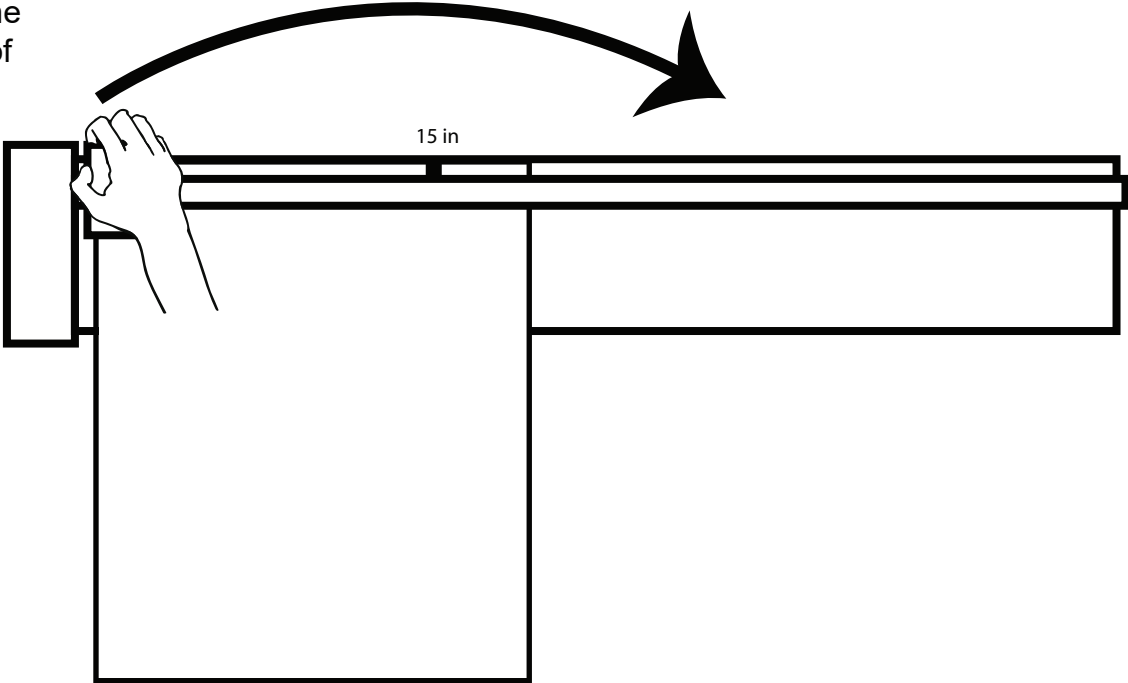

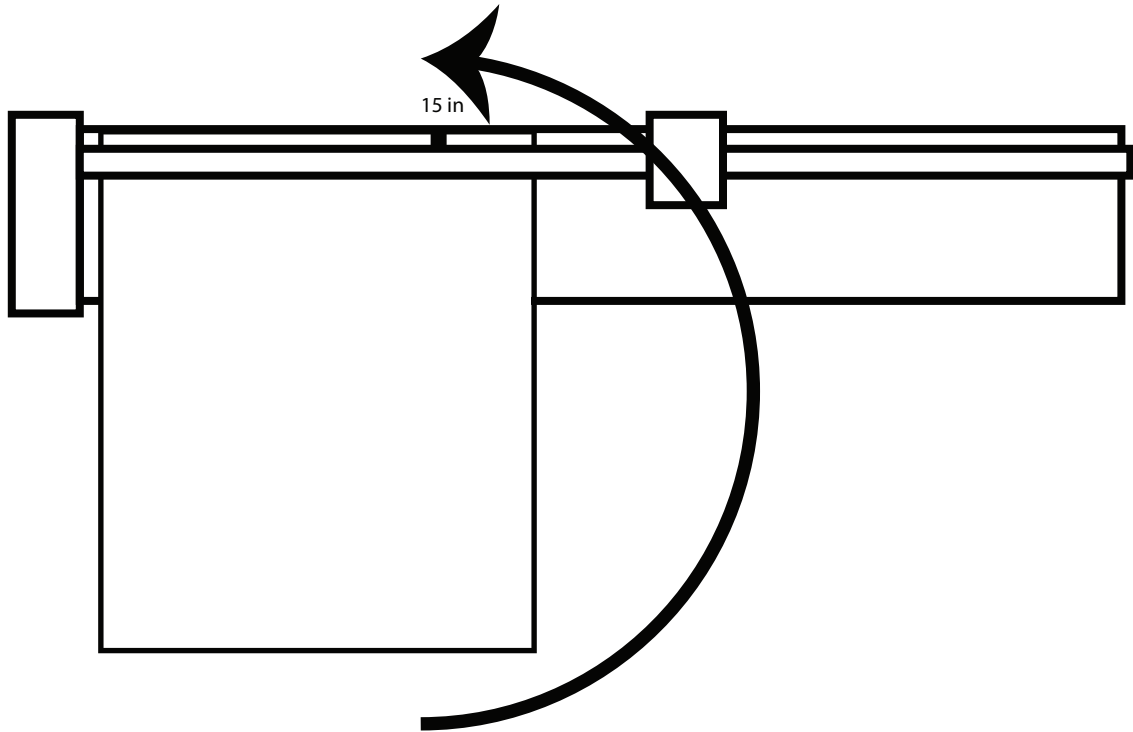

Rotate the paper counter clockwise and line your pencil mark up with the edge of the paper trimmer device

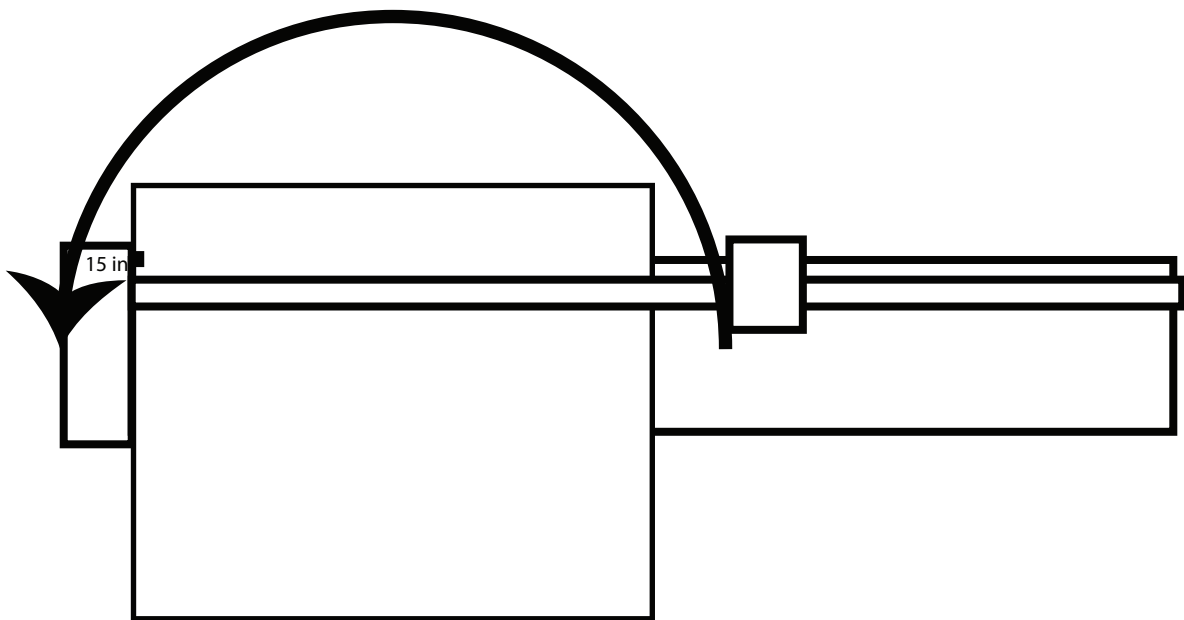

Grasp the paper trimmer blade carriage

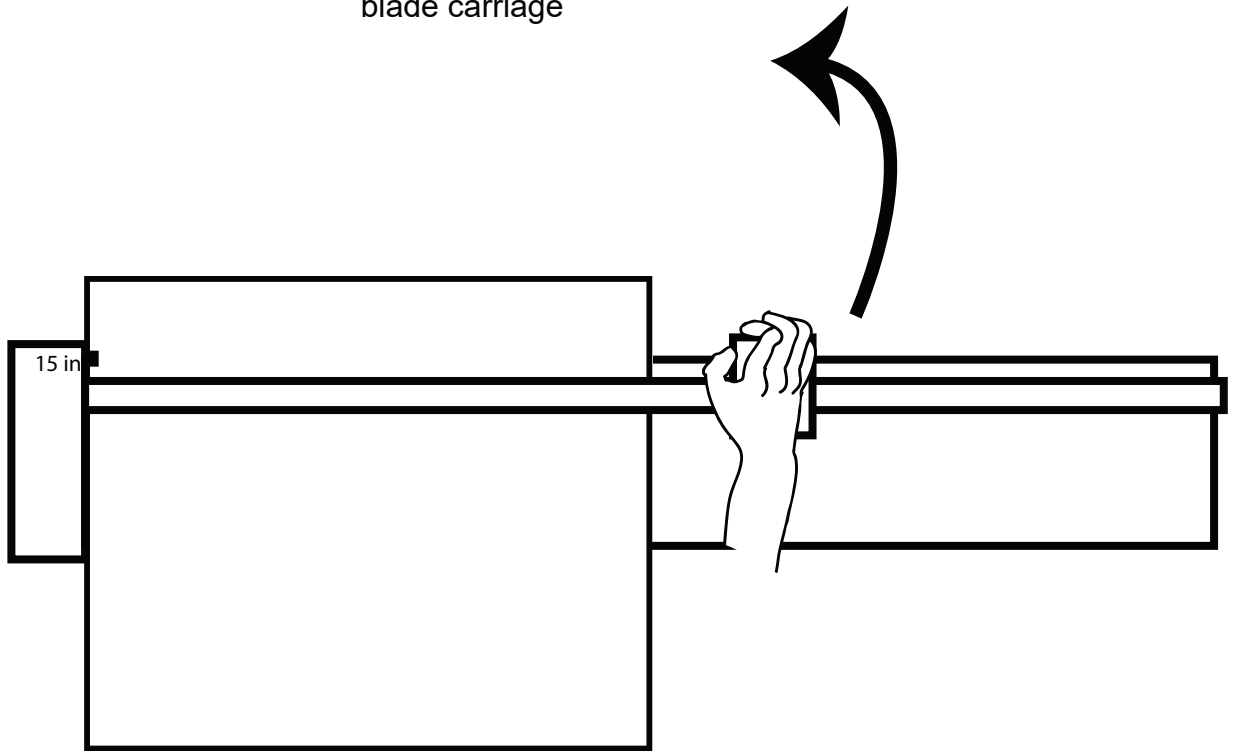

Force the paper trimmer blade carriage toward the left along the transparent guide ruler

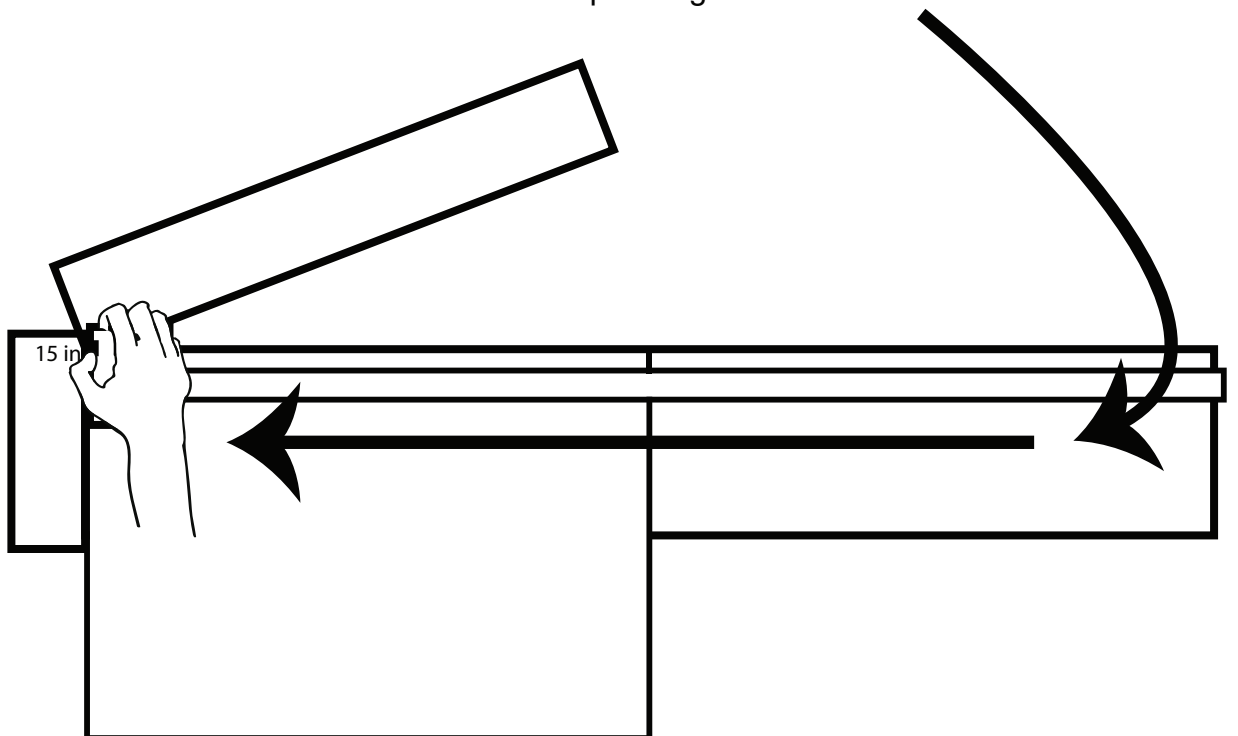

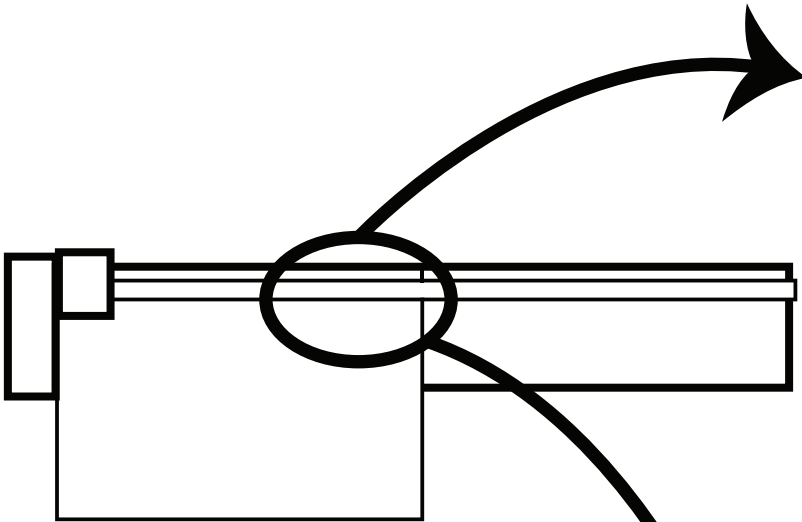
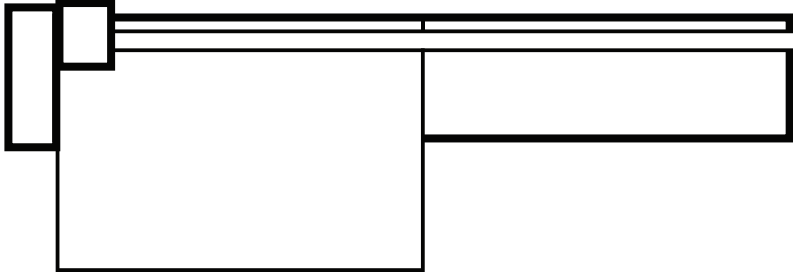

Take the second length of your paper and find it along the paper.

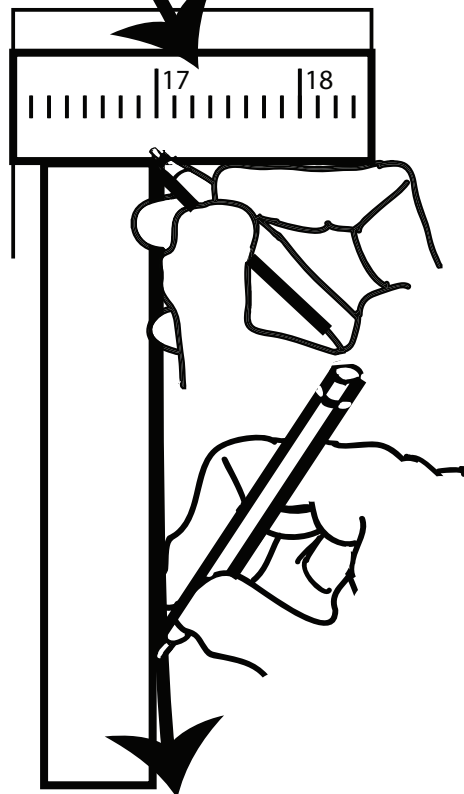

Move the paper trimmer blade carriage to the right to exceed the maximum measure of your paper.

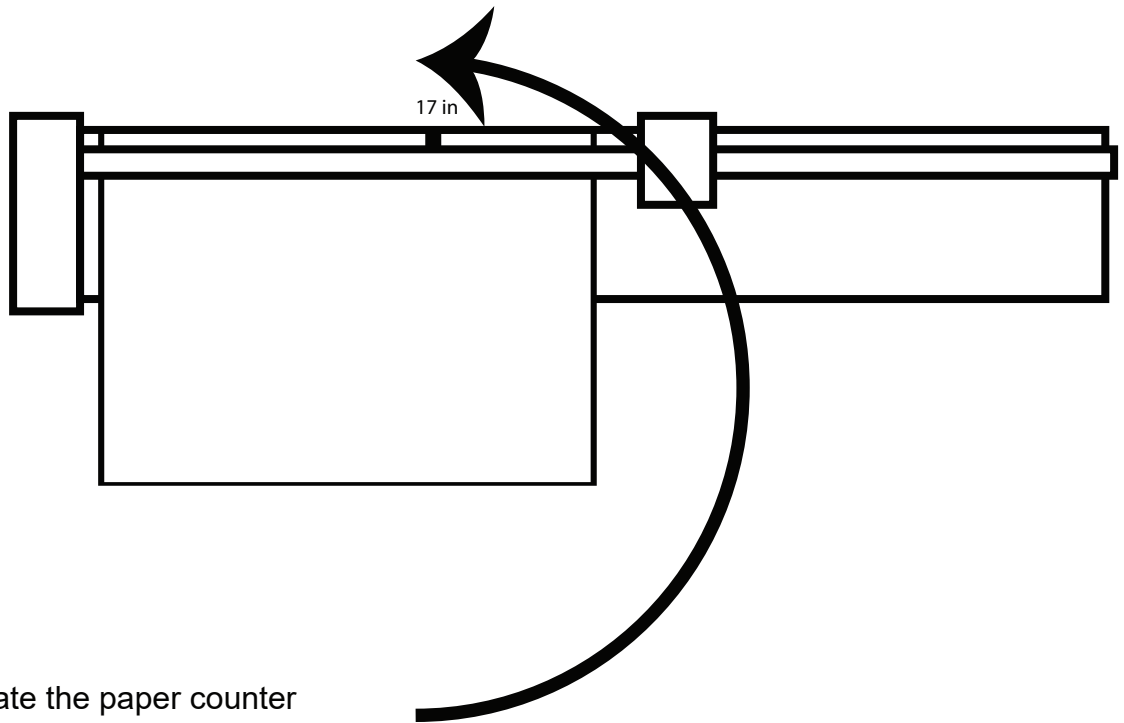
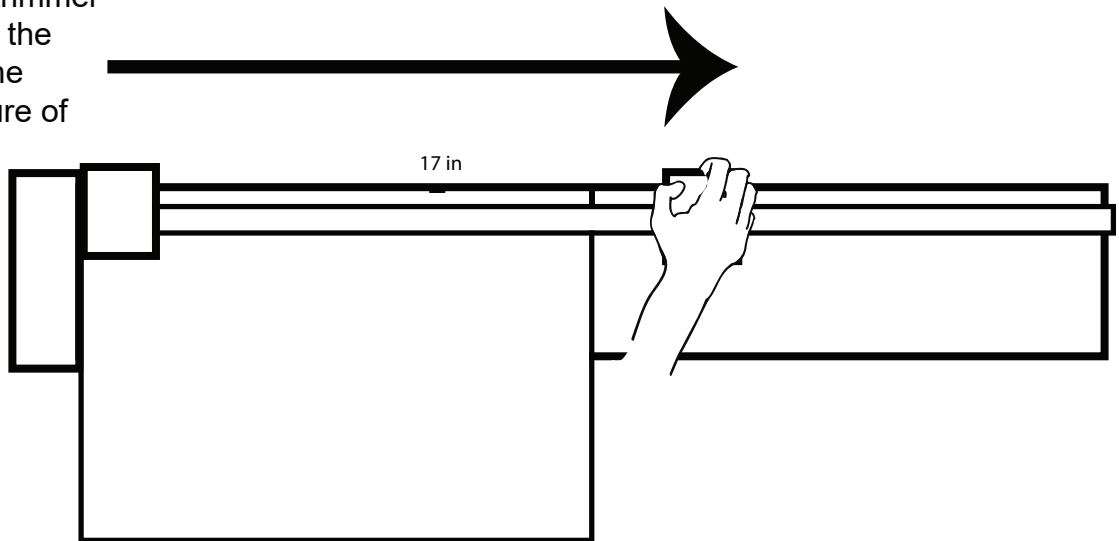

Rotate the paper counter clockwise and line your pencil mark up with the edge of the paper trimmer device

Rotate your paper clockwise
and line your pencil mark up
with the edge of the paper
trimmer device

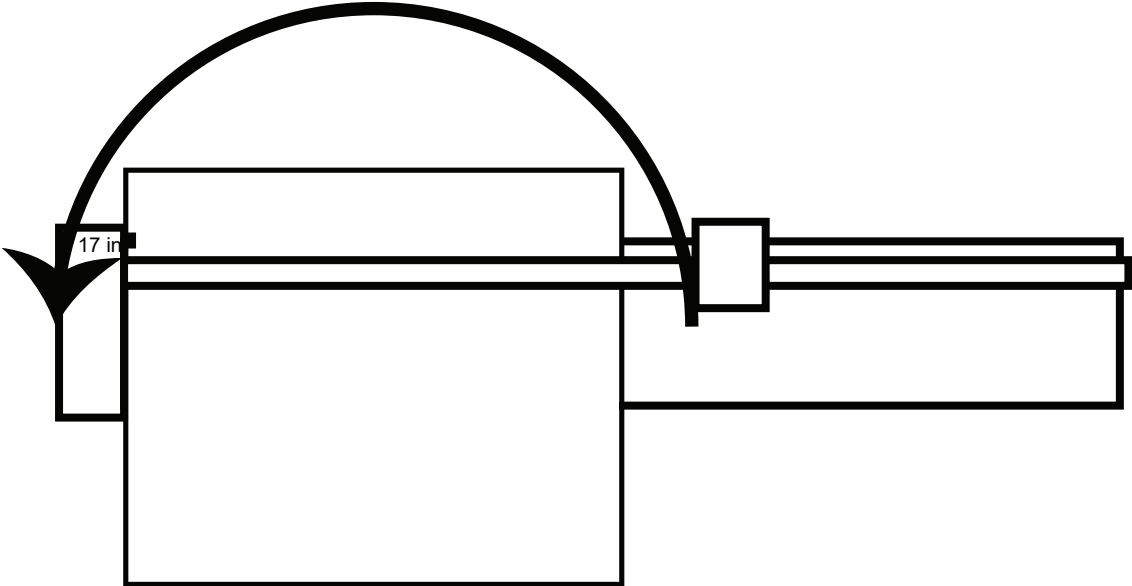

Grasp the paper trimmer blade
carriage

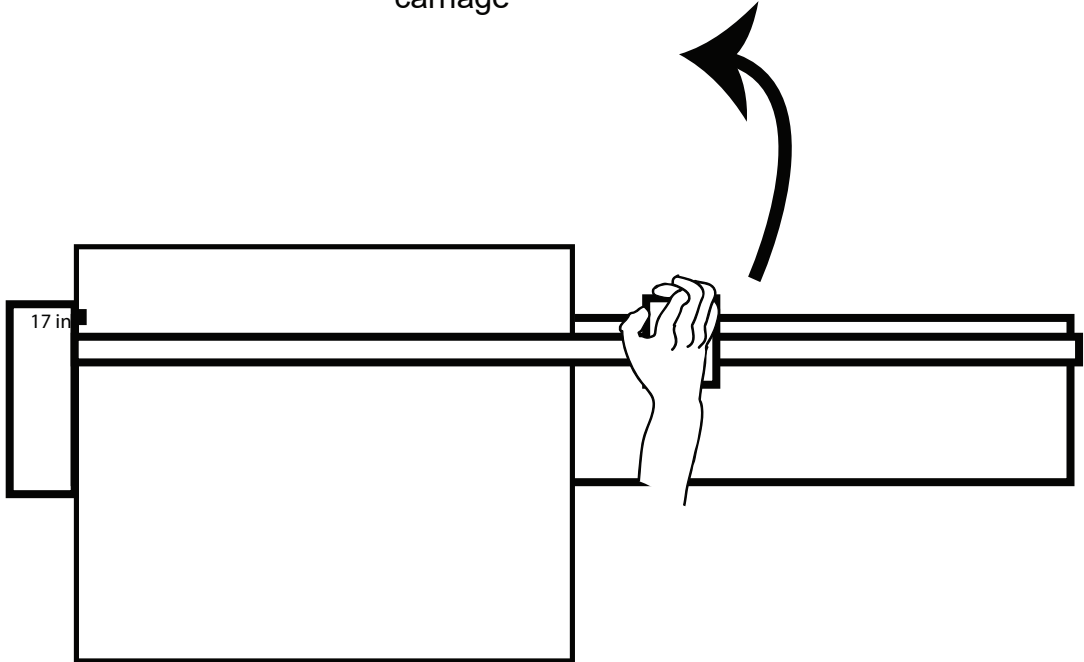

Force the paper trimmer blade carriage toward the left along the transparent guide ruler

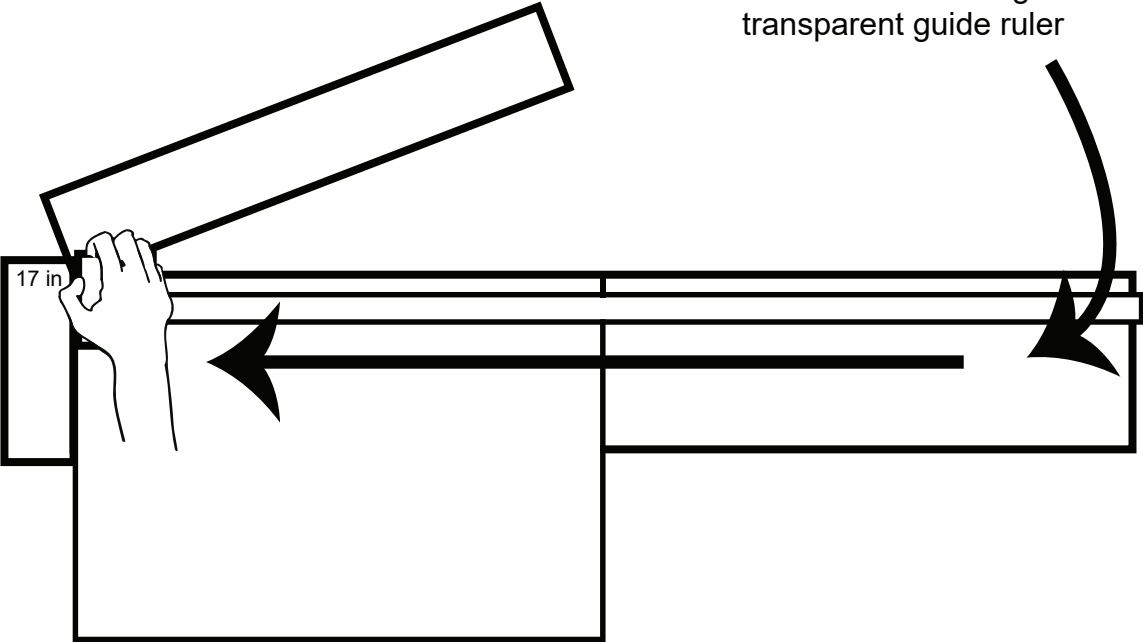

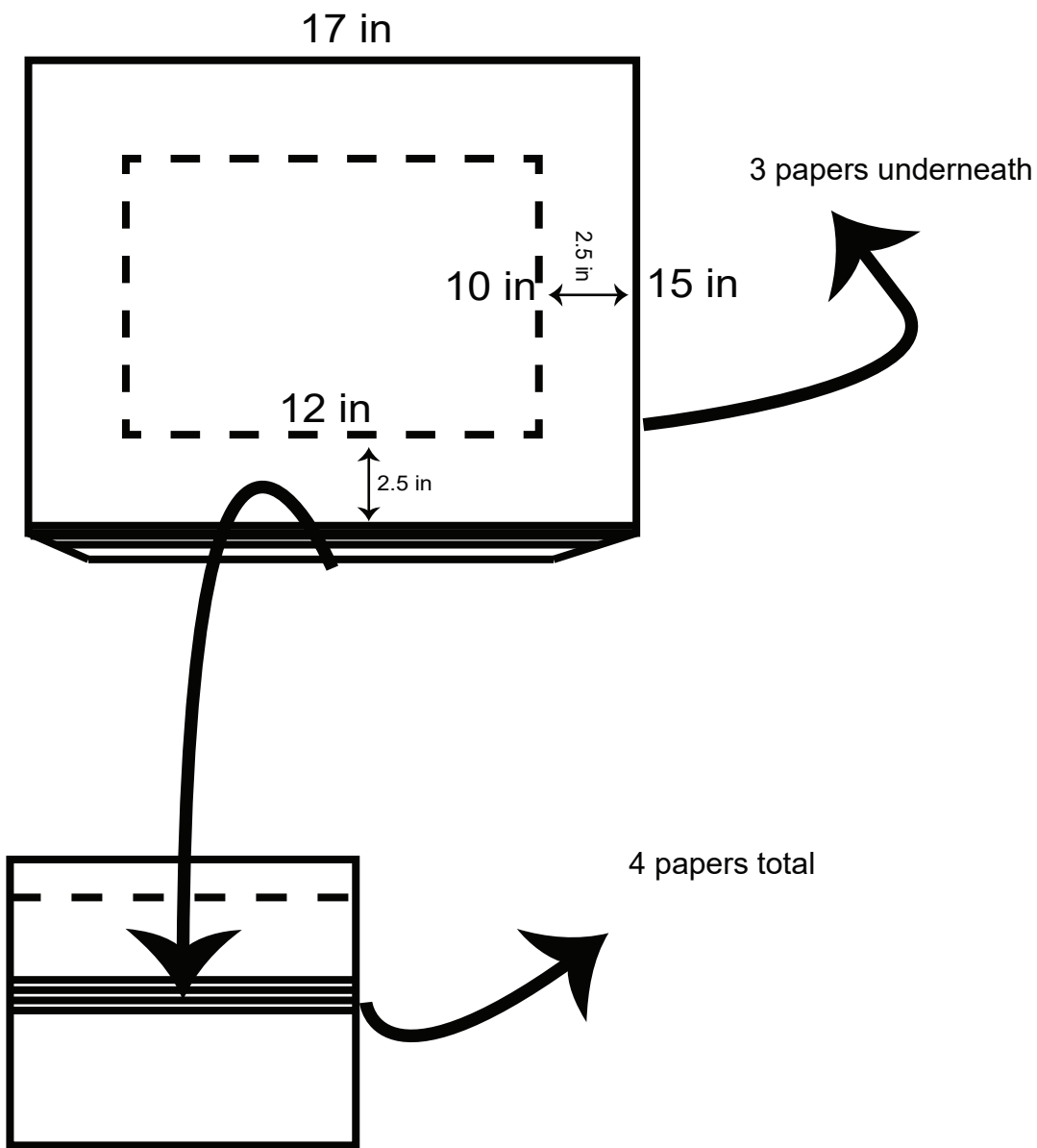

Grasp your stack of papers with both hands and let them fall on a flat surface to straighten them

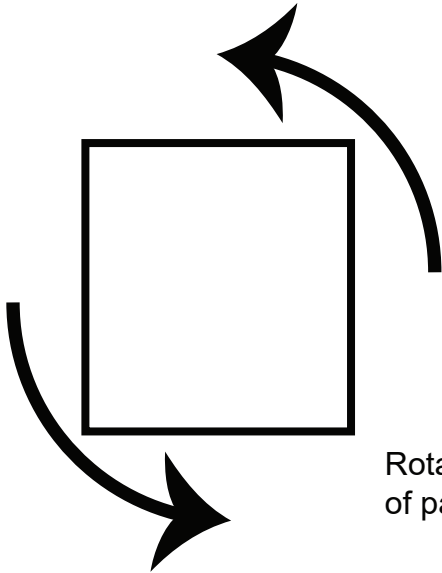

Rotate your stack of papers.

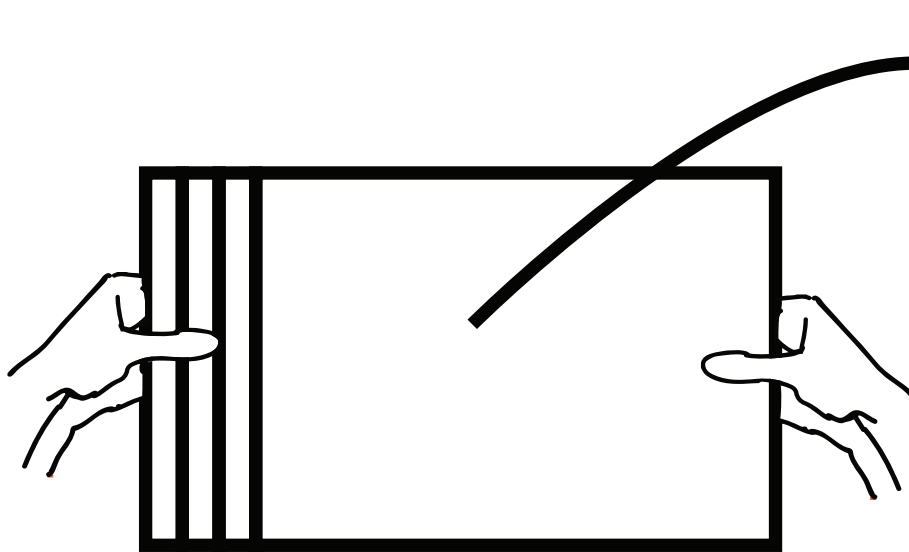
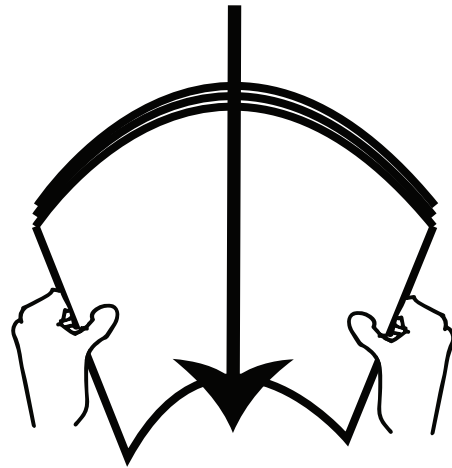

Stagger your papers while holding them and straighten them again

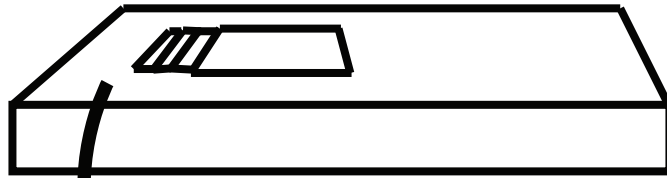

Lay staggered papers on a flat surface

Place ruler across the staggered papers.

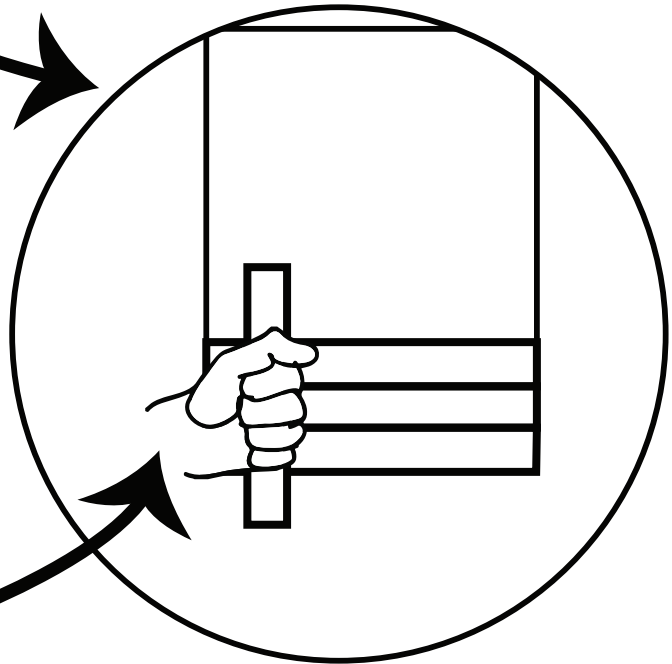

Make one continuous mark along all the staggered papers.

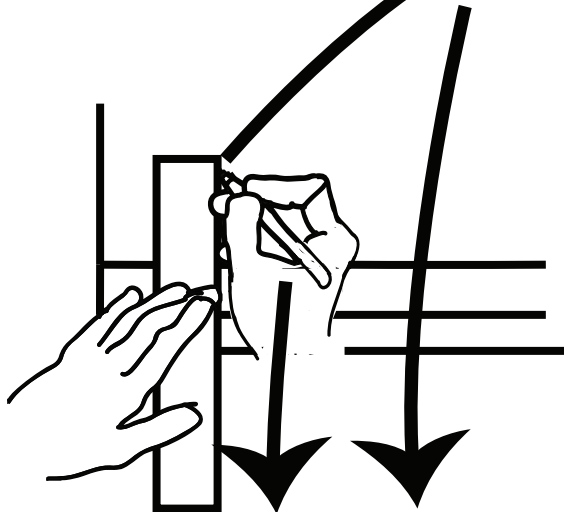

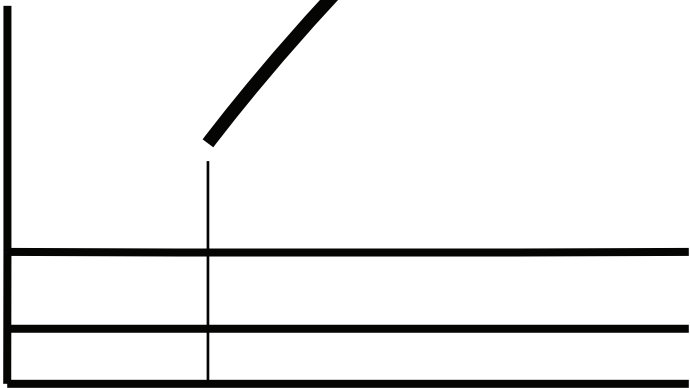

Once you have made a pencil mark down all of your papers, make another on the opposite side

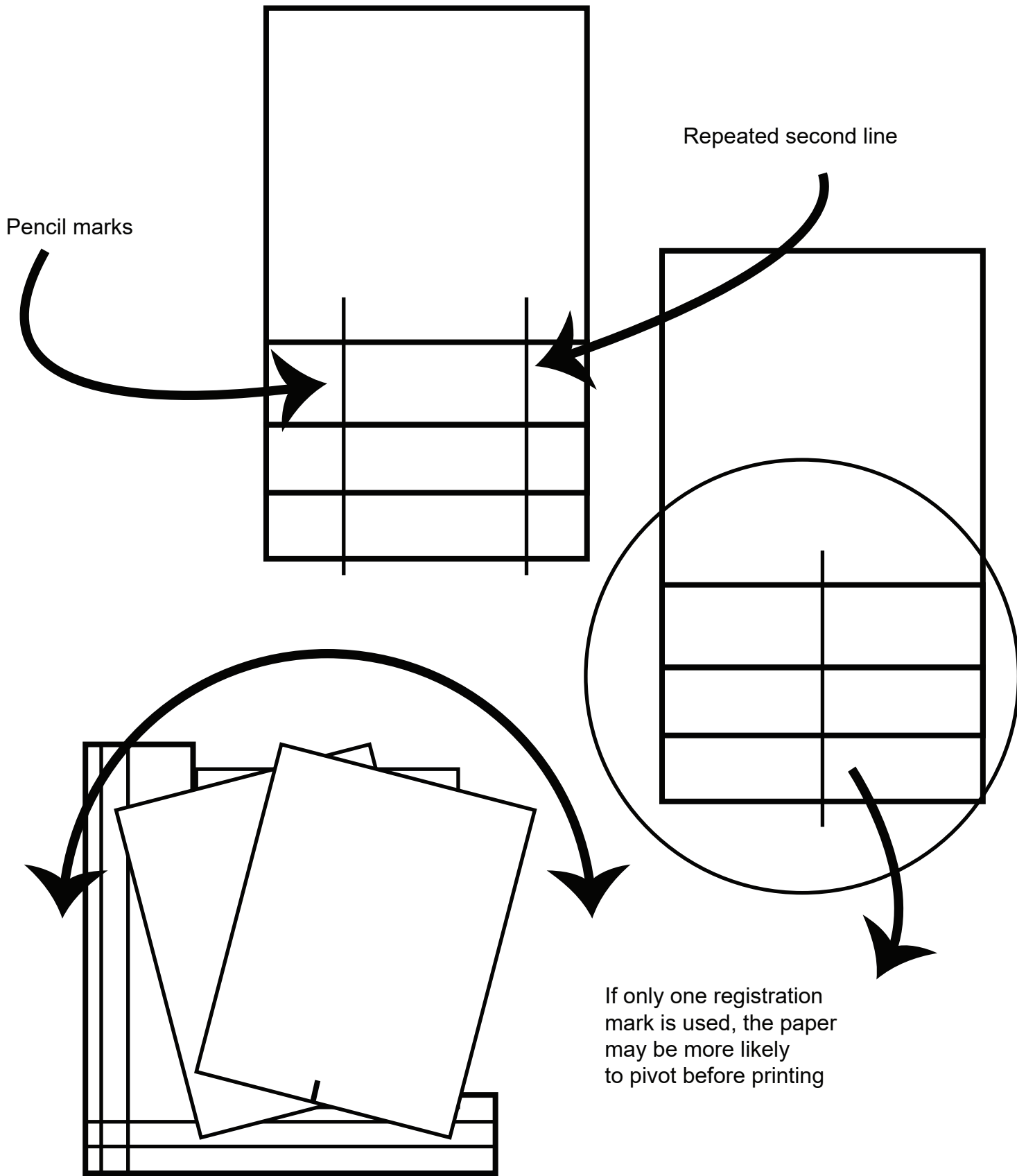

Now that you have the registration marks drawn

Look at the original plan for your print

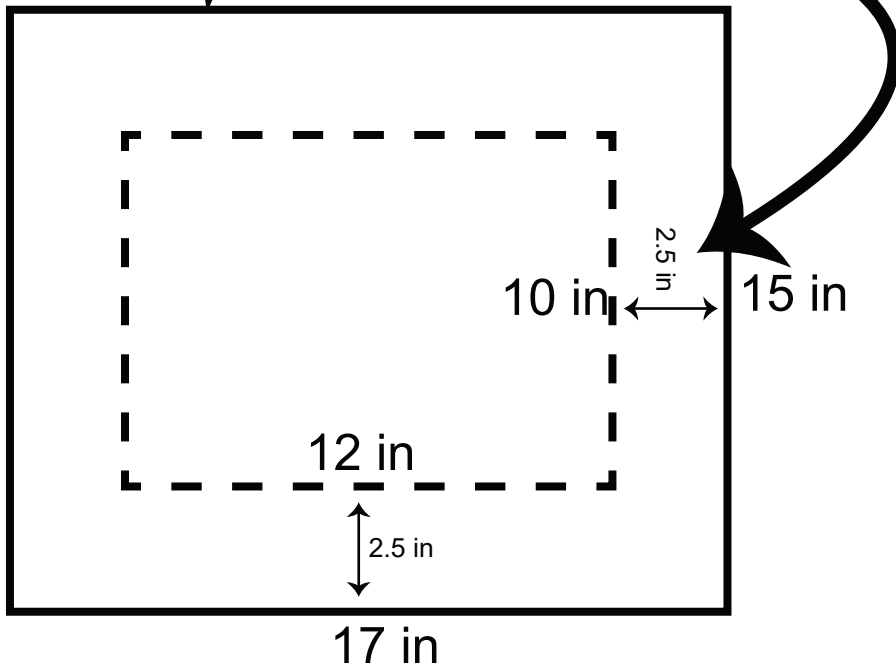

Take your registration bracket and measure 2.5 in from the inside of the bracket

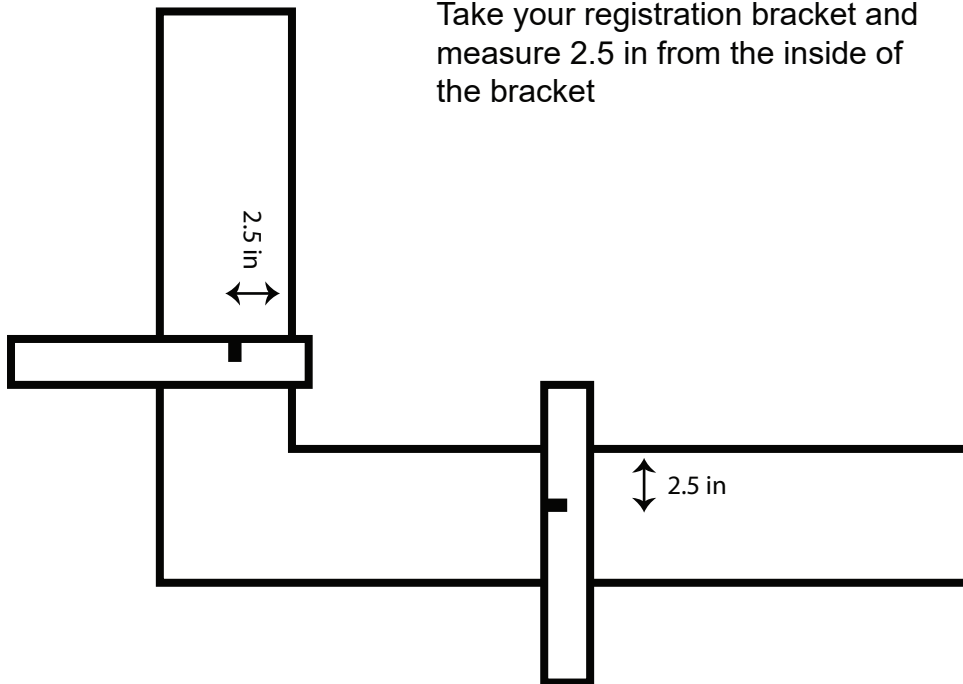

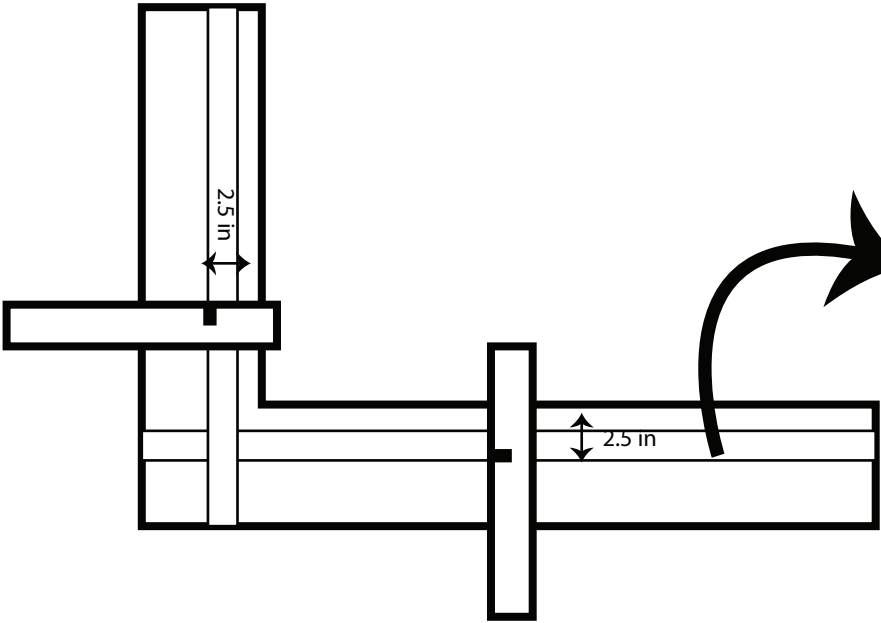

Place masking tape on outer edges

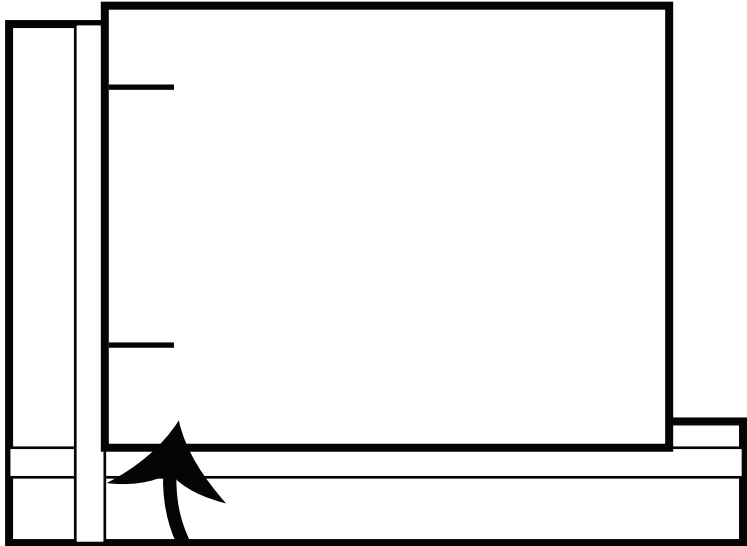

Line your paper up with the tape

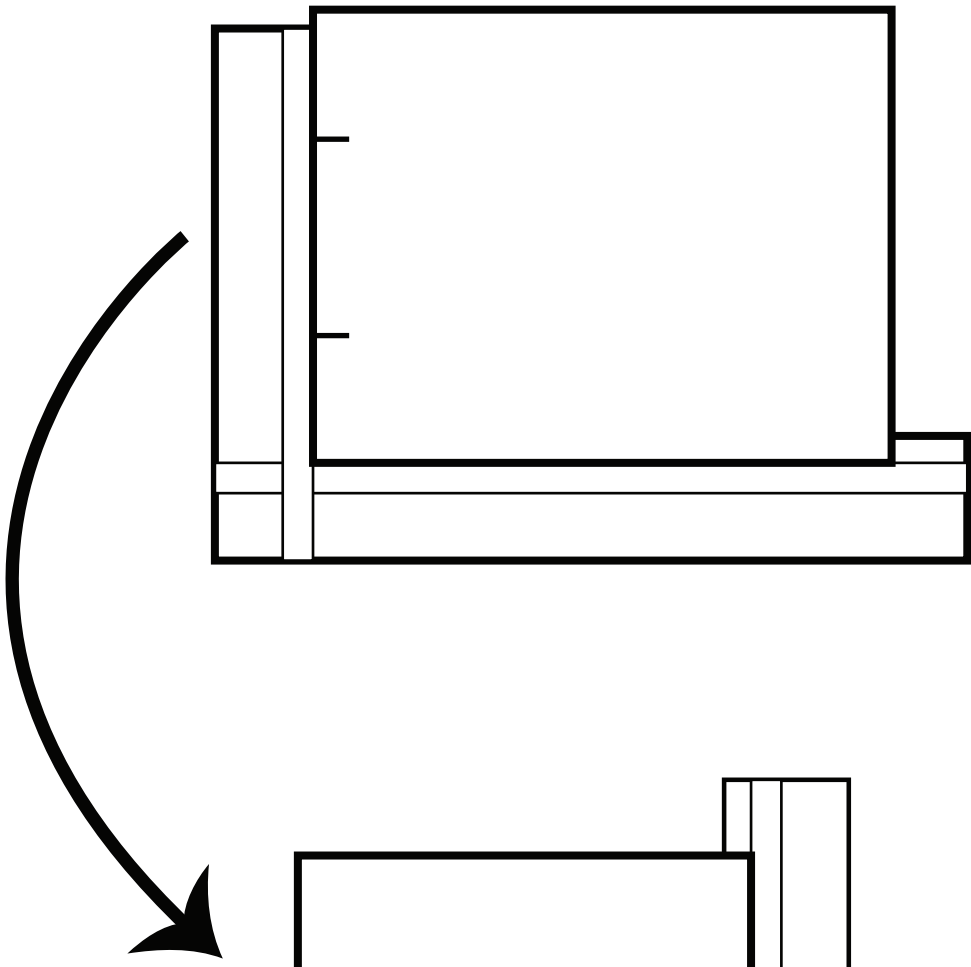

Continue the registration marks on your paper onto the masking tape

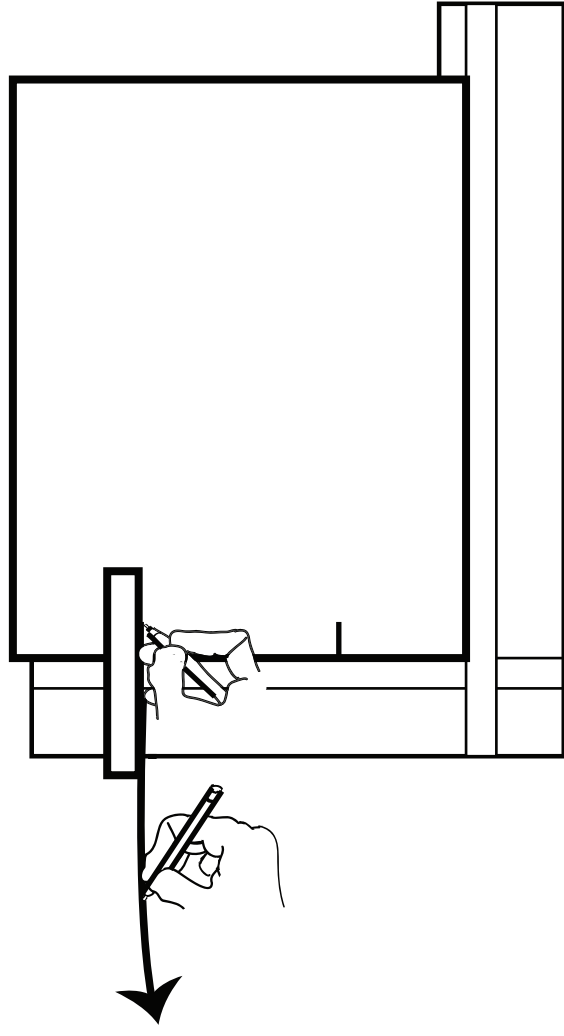

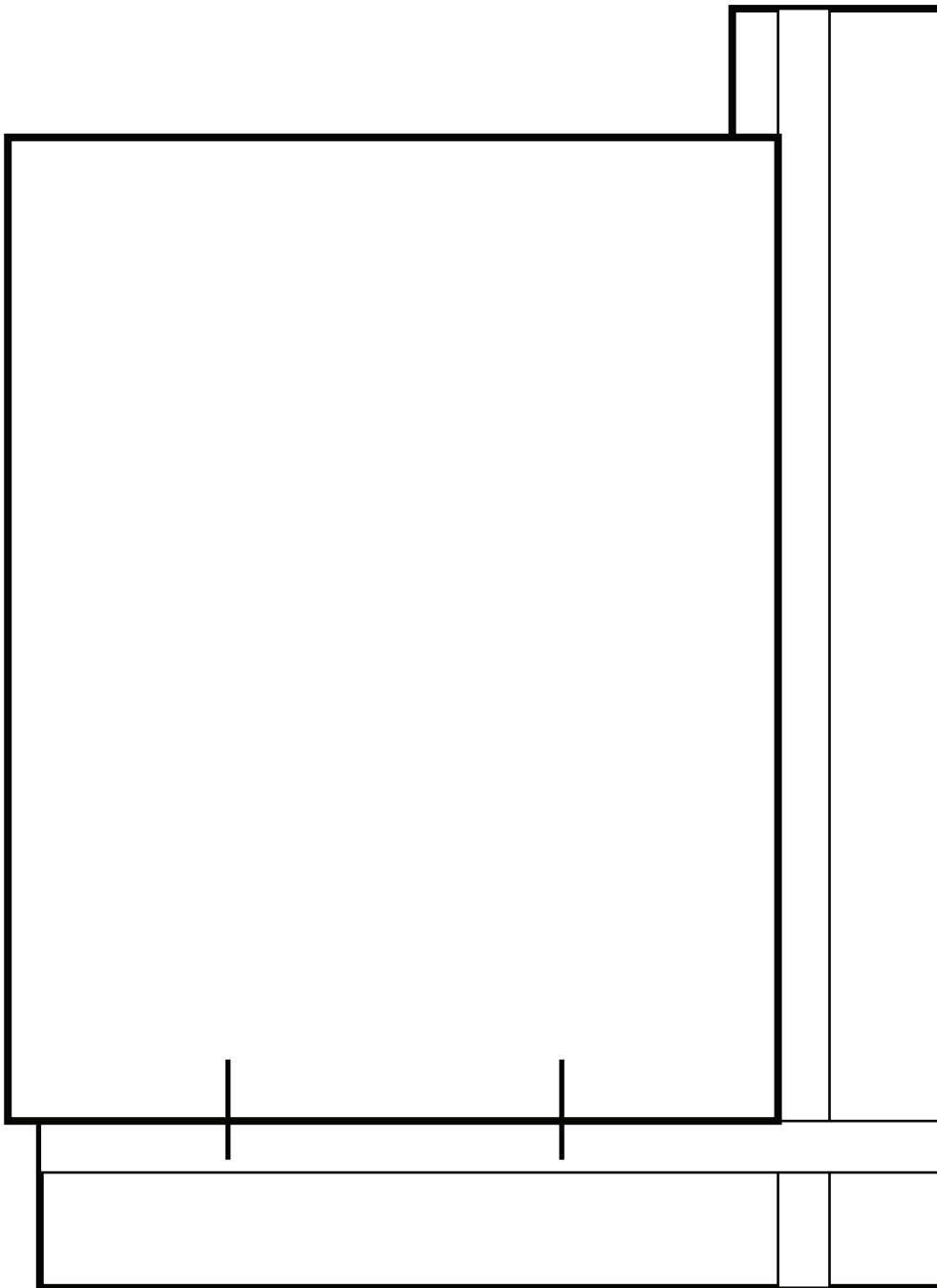

Now that you have completed registration, you are ready to set the pressure on the press

